



# **SAMPLE SYSTEM DESIGN & DIAPHRAGM PUMPS**

By Dan Martin

## **INTRODUCTION**

Sample system design can take many forms, influenced by factors including cost, size, maintenance, source conditions, and analyzer requirements – to mention a few. The following discussion takes into account the operating characteristics of a diaphragm pump, and choices that will improve system performance, reduce measurement errors, and lower pump maintenance. Illustrated below are a few techniques that are commonly used in many sampling systems; this list is not complete, but serves as an introduction to the topic of system design.

### **Section 1**

Discusses sample line sizing and location of pump relative to the sample source connection tap. This may be of little concern for short line lengths, but when long distances are involved, this can be a serious and expensive mistake if not evaluated correctly.

### **Section 2**

Illustrates the effect of pump pulsation, a subject not often considered in sampling system design. Also discussed are filters, used as protective devices in most sampling systems; placement close to the pump will reduce this effect and improve overall system performance – and at little or no additional cost.

Use of a two-head pump with balanced pump stroke design will be of particular interest in those systems where pump selection is marginal, or system design is extremely sensitive to pulsating flows. In some cases, a smaller two-head balanced stroke pump will give better performance than a more expensive single head pump.

### **Section 3**

Reviews the various types of flow and pressure control methods.

The simplest form of flow control is a manual throttle valve in series with the pump; locating the valve before the pump inlet avoids the condition of high diaphragm pressure when valve is located at the pump outlet.

Use of a relief valve or back pressure regulator will reduce the pump diaphragm pressures, as in the case where a throttling valve is located at pump outlet; adding filter(s) will also help system performance.

Description of a system providing constant flowrate independent of source or input pressure is also included. This design may be used for systems that have constant time delay or constant response time requirements.

There are many other techniques that may be used for specific system requirements. We have only touched on a few basic methods, and serve as a beginning for more complicated system designs. For additional information on diaphragm pump sizing and availability, please contact Air Dimensions Inc. at 800-423-6464 or visit the web site at [www.airdimensions.com](http://www.airdimensions.com).

## SECTION 1: PUMP LOCATION / SAMPLE LINE SIZE

A sample pump is required if process pressure is too low to provide adequate pressure for measurement. **Location** of pump and selection of **line size** are the most important factors when dealing with low pressure samples. Piping design is best illustrated by the following example:

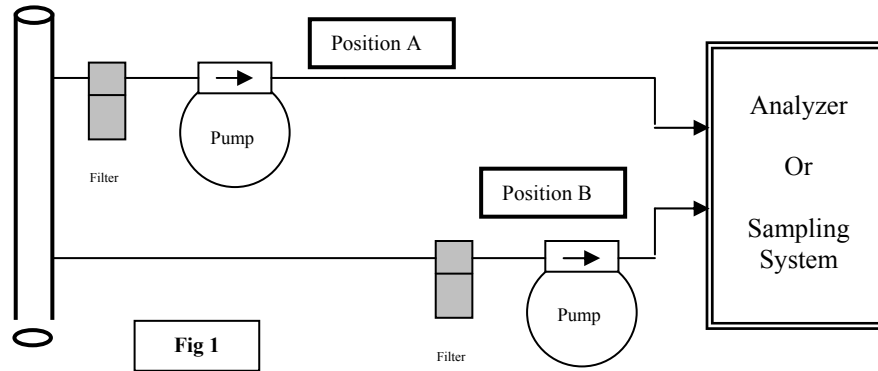

### Requirements:

- Analyzer requirements are 10 SLPM at 14.7 PSIA (Atmospheric Pressure)
- Process pressure is 14.7 PSIA (Atmospheric Pressure)
- Sample line length is 300 Ft
- Note: Filter pressure drop assumed to be negligible

### Choices:

1. Sample line size
2. Pump location and selection of pump

### 1. Sample Tubing Characteristics for flowrate of 10 SLPM

SIZE	I.D.	Line Press Drop - Pos A	Line Press Drop - Pos B
1/4 x .035" wall	.180 inch	20.0 PSIA - 14.7 PSIA = 5.3 PSID	14.7 PSIA - 7.3 PSIA = 7.4 PSID
3/8 x .035" wall	.305 inch	15.0 PSIA - 14.7 PSIA = .3 PSID	14.7 PSIA - 14.3 PSIA = .4 PSID

### 2. Pump Selection

- **Position A** selection dependent on flowrate capacity for inlet pressure at ambient pressure and outlet pressure is sample line backpressure.
- **Position B** selection dependent on reduced pressure at pump inlet (due to sample line loss) and required flowrate with pump outlet at atmospheric pressure.

### 3. Summary

- Comparing tubing pressure drops for pressurized and vacuum sample line conditions illustrates the importance of line size; in addition, a larger displacement pump may be required for smaller line sizes because of vacuum conditions and decrease density.
- Vapor condensation may be a problem if pump is located a long distance from process inlet and sample pressure is reduced below gas vapor pressure.
- Final selection of line size and pump location is effected by many factors, including local codes, environmental considerations, system design, and installation requirements.

## SECTION 2: PUMP PULSATIONS

Connection at pump inlet will see a suction vacuum for one-half of motor shaft rotation followed by “no flow” for remaining half of shaft rotation –the exhaust pulse (flow) portion of pump cycle. As a result, both the inlet and exhaust strokes cause peaked flows several times greater than the average flowrate specified for the pump. This causes several concerns for selection of components (line size, filter, flow indicators, etc) for optimum design. Inlet and outlet conditions are illustrated as follows:

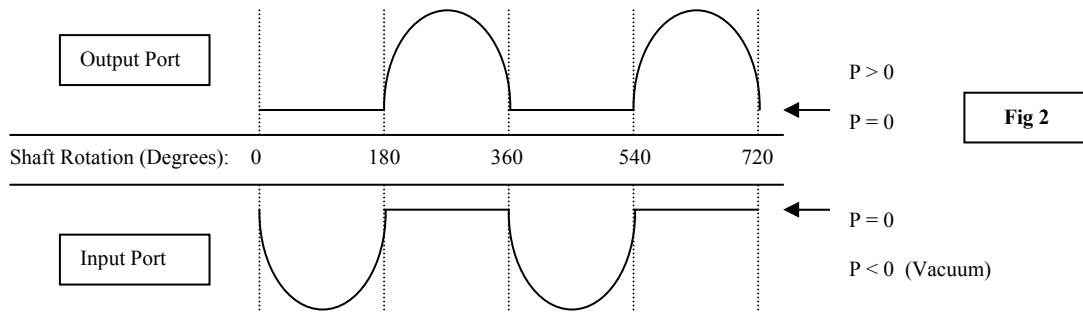

### INLET PULSATION – ACCUMULATOR

A filter is typically installed before the pump to remove contamination from sampling system. Locating the filter close to the **pump inlet** will have the effect of a pulsation dampener, where the inlet suction vacuum is stored in the filter body. This will reduce the vacuum and flowrate peaks and increase average pump flowrate.

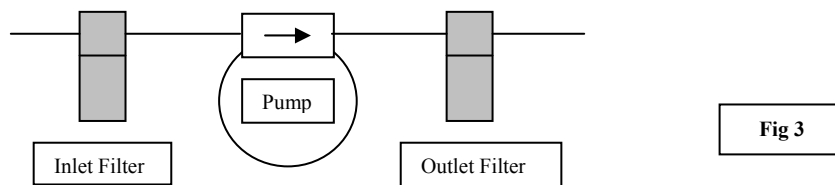

### OUTLET PULSATION – ACCUMULATOR

Addition of a filter at the outlet will reduce the **pump outlet** pressure pulse amplitude. This is important when flowmeters or other pressure-sensitive instrumentation is used, as pulsation will give false readings.

### BALANCED PUMP STROKE DESIGN

A two-head opposed-stroke pump will greatly reduce the effects of pump pulsation. This pump design utilizes two heads oriented 180 degrees out of phase; as one head begins the suction stroke, the other head is starting its exhaust stroke.

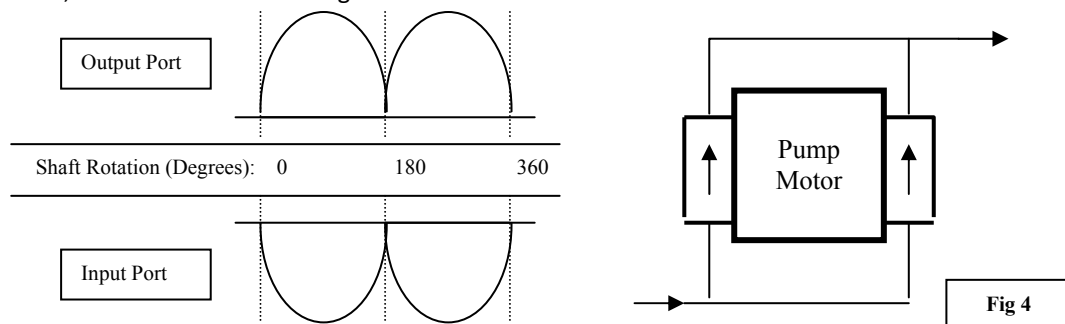

When the inlet and outlet ports of the two heads are connected in parallel, there will be continuous action at the interconnect junctions and no dead time between inlet or outlet pulses. The result of this design is smoother gas flow with greatly reduced pulsation effects at the inlet and outlet connections; in addition, sample line pressure losses are correspondingly reduced because of the reduced peaked and nearly-constant flowrate.

### SECTION 3: FLOW & PRESSURE CONTROL

#### A. CONTROL VALVE

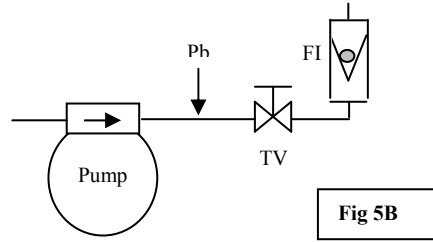
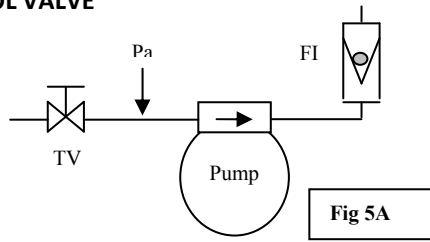

##### Configuration A

Flowrate reduced by increased restriction by Throttle Valve TV, resulting in pressure reduction at **pump inlet**. With TV closed, Pa will decrease to less than -14 PSIG.

##### Configuration B

Flowrate reduced by increased restriction by TV, increasing pressure at **pump outlet** – up to maximum of pump capacity. Depending on pump characteristics, pressure increase at Pb may range from 30 PSIG to 100 PSIG or more.

##### Summary

Excessive pressure on pump diaphragm (Configuration B) will result in increased diaphragm and bearing stress, reducing pump life and increasing service requirement.

#### B. FLOW CONTROL WITH RELIEF VALVE

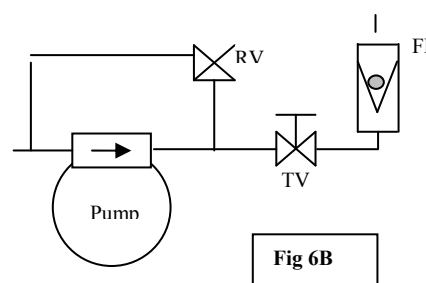
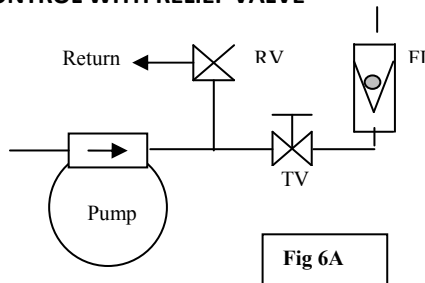

##### Summary

Relief valve reduces high pressure pulses on pump diaphragm, flow pulses will be reduced; return line may be connected to process or pump inlet. (Lowest Cost)

#### C. PUMP OUTLET - CONSTANT PRESSURE

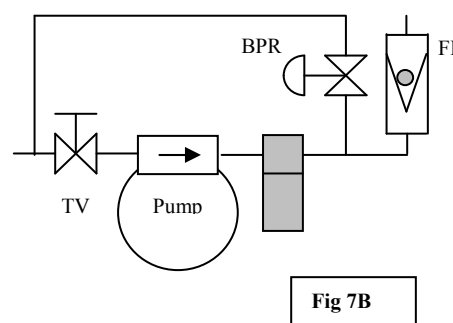
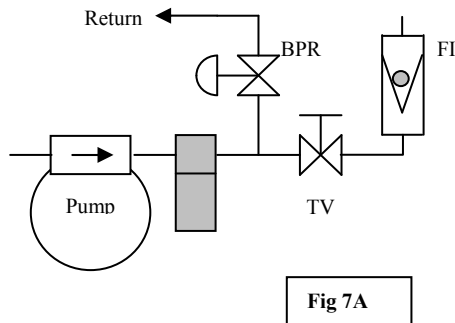

##### Summary

Using BPR will provide better regulation pressure than relief valve. BPR located before analyzer will provide best pressure regulation; filters are optional, and give additional pulsation reduction.

#### D. PUMP OUTLET - CONSTANT SYSTEM FLOWRATE

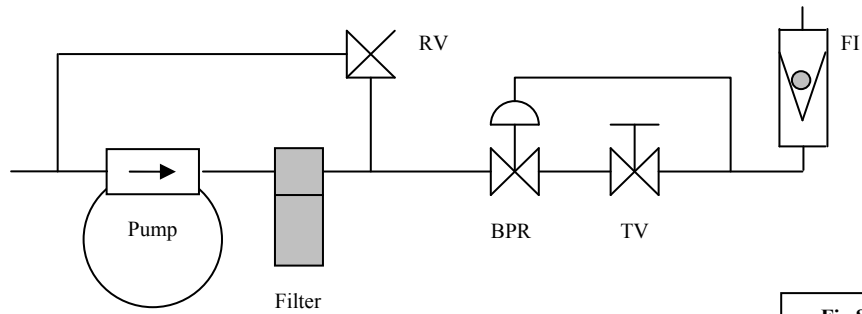

#### Summary

Using a Downstream Pressure Regulator with a Throttling Valve configured as shown above provides constant flowrate independent of upstream pressure (pump side); downstream pressure is assumed to be constant. Moore Industries Model 63BD with the standard 3 PSI spring is typically used for this application.

The above discussion is by no means complete, but is intended to provide a starting point for system design using diaphragm pumps. There are many approaches to sampling system design, some better than others, but "The simplest ways are the best ways."