

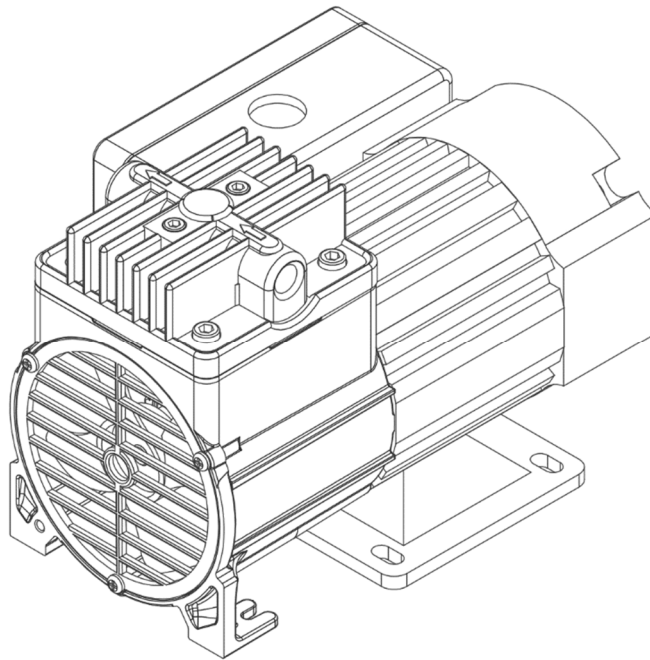

Dia-Vac® Pump Operating Instructions

Standard M-Series Pump with ATEX Zone 2 Motor



Air Dimensions Incorporated

1371 West Newport Center Drive, Suite # 101

Deerfield Beach, FL, 33442

800.423.6464 / 954.428.7333 ph.

954.360.0987 fax

info@airdimensions.com

www.airdimensions.com

General Operating Conditions

Mini Dia-Vac® Zone 2 motors are designed to be used in areas rated as ATEX II 3 G Ex nA IIC T4 Gc.

Dia-Vac® pumps are intended for use with gases only, do not use this product for liquids. For applications where liquid may be present in the gas stream, mount the pump so that the discharge port faces toward the ground. Mounting the pump at the highest point in the system will prevent liquid from collecting in the pump head.

This pump operates at 115 Vac 50/60 Hz or 230 Vac 50/60 Hz depending on the motor. See motor label for wiring diagrams and full electrical data.

The Dia-Vac® Zone 2 pump motor is totally enclosed non-ventilated (TENV) and normally runs warm. It is not an indication of trouble if the outer surfaces of the motor are hot to the touch.

The Dia-Vac® pump normally runs quietly, especially when both pressure and vacuum ports are connected into a closed system. An obvious knock or rattle could indicate a problem. Check through "Troubleshooting" with particular attention to the tightness of all screw fasteners.

Ambient temperature during the operation of this pump should not exceed 40 °C or 104 °F.

Safety

Before running the pump, ensure that it is properly rated for the environment in which it is located. Mini Dia-Vac® Zone 2 motors are designed to be used in areas rated as ATEX II 3 G Ex nA IIC T4 Gc.

All system components connected to the Dia-Vac® pump must be capable of handling its performance.

Ensure that safety regulations are observed when connecting the pump to the electric supply. The connections are to be made in such a way that contact by any object or person with a live wire is impossible. The connections must be protected so no arcing or sparks are possible. The supply voltage must not vary more than $\pm 10\%$ of the voltage shown on the motor plate.

All proper precautions for the controlled vapor must be observed, and followed. Proper wetted materials for handling corrosive, reactive, and/or heated gasses must be used.

This Dia-Vac® pump is not thermally protected and shell temperatures may reach as high as 80 °C (176 °F).

Disassembly of the pump or motor beyond what is detailed in the servicing section below may result in the loss of the pump's hazardous area certification and is highly discouraged.

Operation

No oiling or other lubrication addition is necessary with a Dia-Vac® pump.

If the gas stream has a high level of particulate matter, a filter should be installed before the pump. If the gas stream has a high level of liquid matter, the liquid should be removed before the pump. This should be used in conjunction with best practices for pump installation including mounting the pump head so

that the discharge port faces toward the ground. Keep in mind that the pump head can be rotated on the housing and the gas will always flow in the direction of the arrows.

This pump can be mounted in any position. For vertical mounting, protect the exposed end from direct rainfall. If the housing needs to be rotated for mounting purposes, that can be done at the ADI facility.

Do not start the pump against pressure or vacuum. For applications that must start under pressure or vacuum; contact ADI and a suitable motor will be selected.

Running amps are listed on the motor plate. A pump running at a substantially higher current than shown on the motor plate indicates a problem, please see section "Troubleshooting" below. Please note that the current draw at the startup of the pump will be three to four times that of the normal running current draw.

Air pressurized above atmospheric must not be allowed to flow into the inlet of the pump. For applications with inlet pressure greater than 0 psig; contact ADI and a suitable pump will be selected.

For high pressure applications, outlet pressures above 15 psig, please consult an ADI representative for proper motor sizing.

The diaphragm, valves, gasket, and Teflon® washer of the pump are the most subject to wear. The degree of usage, condition of operating temperatures, and/or pressure will determine the rate of replacement of part(s). For heavy loads (15 psig to maximum pressure) and constant operation the diaphragm should be inspected at least every six months. For lighter loads (0-15 psig or up to maximum vacuum) the diaphragm may operate successfully for a year or more. The corrosive content of the gas media being pumped can affect the recommended inspection and replacement cycle of the diaphragm.

The minimum performance acceptable of a single head of an M-series pump is shown in the table below. Pumps operating at 50 Hz have a 17 percent lower flow rate than their 60 Hz counterparts. To check pumping efficiency, employ suitably damped gauges connected so as to dead-head either pressure or vacuum.

Connecting to the Junction Box

An A2F cable gland with ½" NPT threads is required to connect power wires to the junction box. There are 3 acceptable cable gland sizes for this junction box: 20S/16, 20S, and 20. To maintain the IP rating of the equipment and cable gland, it is also important to fit an entry thread seal at the interface between the gland and the exterior of the junction box. This seal must be compatible with a ½" NPT thread. A ½" NPT serrated washer and lock nut should be used within the junction box to secure the cable gland. The serrated washer must be placed in between the interior of the junction box and the lock nut for proper sealing.

Minimum Performance Requirements

M-Series Product 60 Hz (50 Hz)

Eccentric	Max Press PSIG Minimum	Open Flow LPM Minimum	Ult Vac In Hg Minimum
M16x	30	19 (16)	19
M15x	25	18 (15)	18
M14x	22	17 (14)	17
M12x	16	15 (12)	16
M10x	12	13 (11)	13
M08x	8	10 (8)	11

NOTE: Check each separately, one or the other port must be open during this test. Use 0-60 PSI pressure gauge and 0-30 inch Hg vacuum gauge, (or mercury manometer.)

Troubleshooting

If a problem occurs, the pump may require inspection at the ADI facility. To have your pump inspected and repaired at the ADI facility please follow the instructions on the ADI website located at <http://www.airdimensions.com/service/rma/>.

Pump draws excessively high current

- Motor is overloaded
 - Turn off pump
 - Remove all pressure and vacuum conditions
 - Restart and test at atmospheric pressure
- Power input is incorrect
 - Check motor wiring i.e. 115 V vs 230 V wiring
 - Check power source
 - Pumps are only rated for $\pm 10\%$ voltage on name plate
 - Confirm pump is rated for input frequency i.e. 50/60 Hz

Little to no flow is being produced

- Connections or lines are blocked
 - Remove blockage
- Liquid or foreign debris has collected in the head

- Clean out the head, see section “Servicing”
 - Place pump outlet facing downward
- Diaphragms, valves, and/or gaskets are worn
 - See section “Servicing”

Pump is rattling or knocking

- Diaphragm plate screw is under torqued
 - See section “Servicing” for torquing specifications

Servicing

Listed below is the predominant type of maintenance typical for Dia-Vac® pumps, the servicing of the consumable parts (diaphragm, valves, gasket, and Teflon® washer). For video instructions on servicing the head and diaphragm visit <http://www.airdimensions.com/service/videos/>.

Disassembly of Head Section and Diaphragm

Remove head section by unscrewing the four large bolts. A flat-bladed screw driver may be needed to gently pry the head free of the service diaphragm. **If the heads have Teflon® coating use caution not to scratch the surface.

The valve body can then be removed by unscrewing the two smaller screws (also accessible on the top of the head section). This part may be freed by gently tapping on these two screws after they have been loosened about three or four turns. When the valve body is removed, check all internal surfaces for any accumulation of dirt. The two valve discs can be wiped clean and replaced as long as they appear unaffected by usage. The valve gasket can be easily removed and should be inspected. As a matter of good practice, the valve discs and valve gasket should be replaced during any routine maintenance check of the head section. A once a year routine procedure is recommended.

The diaphragm is secured by the single screw in its center. Remove this screw with an Allen wrench. The diaphragm and its clamping plate should be easily lifted off. Some slight adherence to the metal may occur if the diaphragm has been in use for a long period.

To reattach diaphragm, first insert the diaphragm plate screw through the Teflon® washer, then through the diaphragm plate, then finally through the diaphragm. Next apply a drop of a screw adhesive such as Loctite 242 to the screw. Then you can screw it back into the Connecting Rod.

Due to the sensitive nature of the pump to any small changes in the head or diaphragm assembly, it is recommended that the instructions illustrated in the video listed above are followed verbatim.

The torque specifications for this pump can be found in Appendix A.

If a problem occurs, the pump may require inspection at the ADI facility. To have your pump inspected and repaired at the ADI facility please follow the instructions on the ADI website at <http://www.airdimensions.com/service/rma/>.

Spare Parts

Module	Description
11305	KIT, REPAIR – TEFLON®/ EPDM
11311	KIT, REPAIR – ALL TEFLON®

Warranty

All Air Dimensions Incorporated Dia-Vac® pumps are under warranty for 12 months from the ship date. The warranty does not cover consumable parts (diaphragm, valves, gasket, and Teflon® washer). For complete terms and conditions please see Appendix C.

Appendix A - M-Series Torque Chart

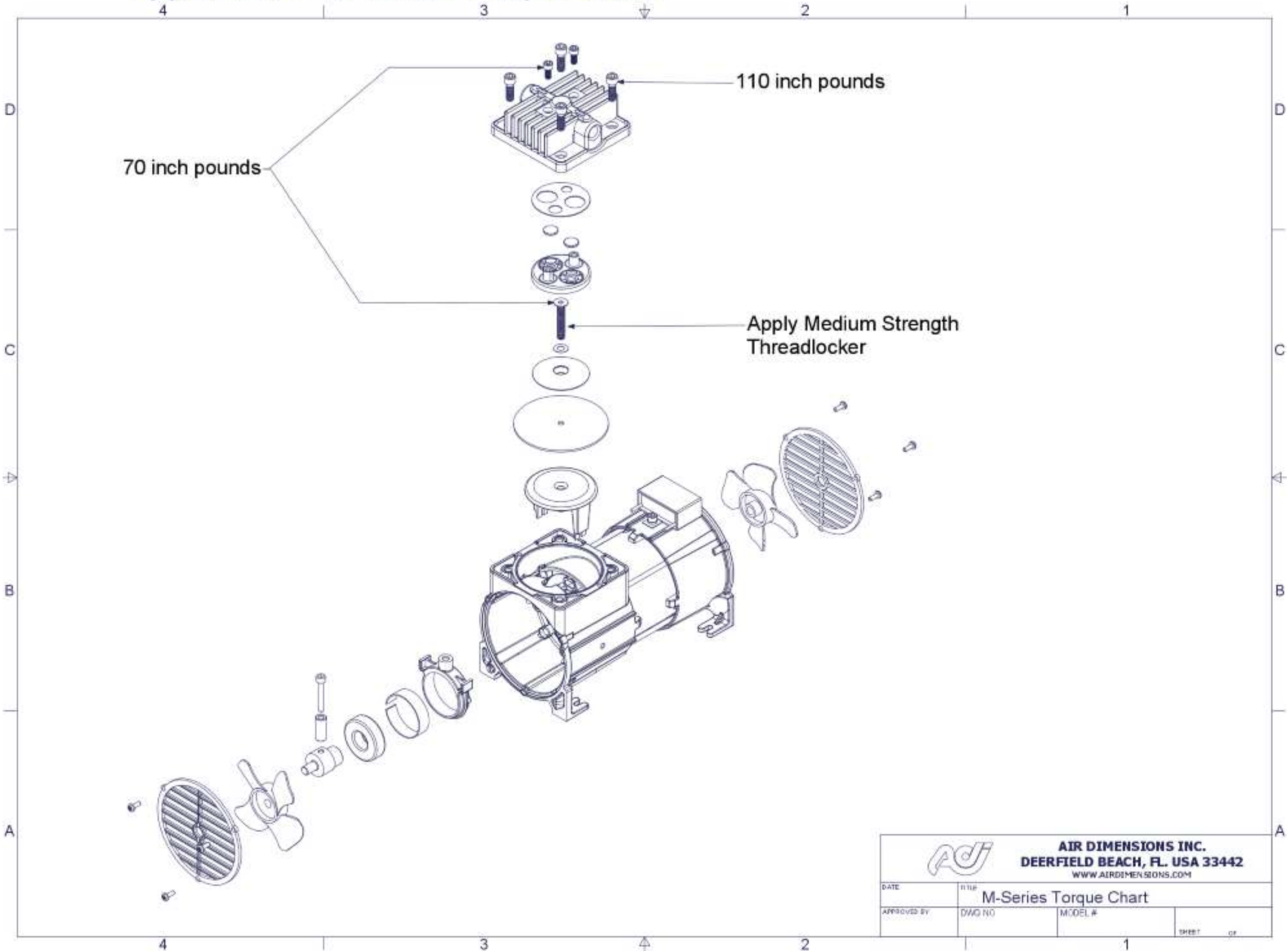

 AIR DIMENSIONS INC. DEERFIELD BEACH, FL. USA 33442 WWW.AIRDIMENSIONS.COM			
DATE	TITLE M-Series Torque Chart		
APPROVED BY	DWG NO	MODEL #	SHEET OF

Appendix B- Maximum Gas Temperature for ADI Diaphragms

<u>Diaphragm Material</u>	<u>Max Temperature</u>
---------------------------	------------------------

Teflon Coated EPDM	250 °F (121 °C)
--------------------	-----------------

All Teflon	400 °F (205 °C)
------------	-----------------

Appendix C- TERMS AND CONDITIONS OF ACKNOWLEDGMENT OF ORDER

1. **EXCLUSIVE REMEDY.** Seller will replace or, at its option, repair any products or parts thereof which are found defective by Seller in material or workmanship within one year from date of shipment, provided the product has been properly installed, maintained and operated. Seller's obligation with respect to such products will be exclusively limited to repair or replacement F.O.B. Deerfield Beach, Florida, U.S.A., and in no event shall Seller be liable for consequential or special damages, or for transportation, installation, adjustment, or other expenses which may arise in connection with such products. **NO EXPRESS WARRANTIES AND NO IMPLIED WARRANTIES WHETHER OF MERCHANTABILITY OF FITNESS FOR ANY PARTICULAR USE, OR OTHERWISE (EXCEPT AS TO TITLE), SHALL APPLY TO PRODUCTS SOLD BY US, AND NO WAIVER, ALTERATION, OR MODIFICATION OF THE FOREGOING CONDITIONS SHALL BE VALID UNLESS MADE IN WRITING AND SIGNED BY AN OFFICER OF SELLER.**
2. **METHOD OF SHIPMENT.** This apparatus will be shipped "knocked down" to the extent we consider necessary for proper shipment with small parts.
3. **SHIPMENT.** All goods are shipped F.O.B. shipping point which shall be Deerfield Beach, FL unless otherwise specified. Risk of loss of damage to goods in transit shall fall upon Buyer.
4. **TERMS.** Subject to any prior written agreement to the contrary, and to approval of credit, payment for products shall be made net 30 days from date of invoice. If in Seller's opinion the financial condition of Buyer does not justify continuance of production or shipment on the terms of payment specified, Seller may, at its option, require full or partial payment in advance. Seller reserves the right to issue an invoice if shipment is delayed due to Buyer's responsibility, request or if partial shipment occurs. Goods held for Buyer shall be at the risk and expense of Buyer. All bank and collection charges are for Buyer's account.
5. **TAXES.** In addition to the purchase price, Buyer shall pay or upon receipt of invoice from Seller shall reimburse Seller for all sales, use, occupation, gross income, excise, documentary stamp, and other taxes, assessed or imposed by Purchaser, or on the machine as required to be collected by Seller, by reason of or on account of the delivery, purchase, or sale of any article here under or the execution of this contract.
6. **PATENT INDEMNITY.** Buyer shall indemnify and hold Seller harmless against any loss, liability or expense, including reasonable attorney's fees, resulting from infringement or patents or trademarks arising from compliance with Buyer's design, specifications or instructions. Upon notification by Seller, Buyer shall at its sole expense undertake the complete defense of all lawsuits or other proceedings brought under this paragraph. Buyer agrees that it will not reproduce any of the aforementioned equipment in whole or part for the purpose of use or resale or for any other purposes without the Seller's written consent.
7. **DELAYS.** Shipping dates are approximate and are based upon prompt receipt of all necessary instructions and information which will enable Seller to immediately start shop construction. Seller shall not be liable for delay in delivery due to causes beyond its reasonable controls such as acts of God, acts of Buyer, acts of civil or military authority, priority, fires, strikes, floods, epidemics, quarantine restrictions, war, riot and delays in transportation. In the event of delay due to such causes, the date of delivery shall be extended for a period equal to the time lost by reason of delay. If by reason of any of the foregoing events or conditions shipment is delayed more than one year beyond the period specified herein, either party may terminate this contract by written notice to the other, and in that event Seller shall return to Buyer all payment previously made hereunder without interest.
8. **STANDARD PRICES.** Prices shown are standard to Industry and U.S. government for a like quantity and model.
9. **CLAIMS.** All claims must be made in writing within 30 days of receipt of goods; otherwise such claims shall be deemed waived and released by Buyer.
10. **DEFAULT.** In the event of a default by Buyer, Seller may, in addition to all other remedies it may have as a result of such default, elect to retain any and all payments made by Buyer hereunder as liquidated damages.

11. **RETURN OF GOODS.** No materials shall be returned without authorization and shipping instructions first being obtained from Seller. Unless Seller specifically and expressly agrees otherwise, freight forwarding, transportation and other associated shipping costs and customer clearance charges shall be paid by Buyer.

12. **CONTROLLING PROVISIONS.** These terms and conditions shall supersede any provisions, terms and conditions contained on any purchase order, or other writing Buyer may give or have given, and the rights of the parties shall be governed exclusively by the terms and conditions hereof.

13. **MERGER CLAUSE.** This writing constitutes the final expression of the parties' agreement, and it is a complete and exclusive statement of the terms of that agreement. The terms and conditions herein contained shall supersede all prior oral or written statement of any kind whatsoever made by Seller or its representative.

IMPORTANT

This merchandise was carefully packed and thoroughly inspected before leaving our factory. Responsibility for its safe delivery was assumed by the carrier upon acceptance of the shipment. Claims for loss or damage sustained in transit must, therefore, be made upon the carrier as follows:

CONCEALED LOSS OR DAMAGE

Concealed loss or damage means loss or damage which does not become apparent until the merchandise has been unpacked. The contents may be damaged in transit due to rough handling even though the carton may not show external damage. When the damage is discovered upon unpacking, make a written request for inspection by the carrier's agent within fifteen days of the delivery date. Then file a claim with the carrier since such damage is the carrier's responsibility. By following these instructions carefully, we guarantee our full support of your claims to protect you against loss from concealed damage.

VISIBLE LOSS OR DAMAGE

Any external evidence of loss or damage must be noted on the freight bill or express receipt, and signed by the carrier's agent. Failure to adequately describe such external evidence of loss or damage may result in the carrier refusing to honor a damage claim. The form required to file such a claim will be supplied by the carrier.

**DO NOT RETURN DAMAGED MERCHANDISE TO US
FILE YOUR CLAIM AS ABOVE**